

GENERAL INFORMATION

Project Name: _____

STANDARD SPECIFICATIONS

- 1" Diameter Post & Bracket in Brushed Stainless Steel Finish
- 3/8" Clear Tempered Front Glass Panels (max. span 66")
- 1/4" Clear Tempered Glass End Panels
- 1" Radius Glass Corners

OPTIONS AND ACCESSORIES

NSF-LISTED FINISH OPTIONS

- Brushed Stainless (Standard)
- Gloss Black

GLASS THICKNESS

- 1/4" Clear Tempered Front Glass Panels (max. span 54" - not for shelves)
- 3/8" Clear Tempered Front Glass Panels (max. span 66") (Standard)
- 1/2" Clear Tempered Front Glass Panels (max. span 72" - for shelf or span more than 66")

GLASS FINISHES

- Clear (Standard)
- Frosted
- Pattern
- Low Iron
- Frosted Logo/Imprint

GLASS CORNERS

- 1" Radius Corners (Standard)
- Square Corners

LIGHT & WARMER OPTIONS

All BSI light units are UL Listed. See light spec sheets for detailed information. Also available with other manufacturers' light units. Contact BSI for details.

Model #	Description
<input type="checkbox"/> 2580	Slimline LED Light
<input type="checkbox"/> 705	Stealth Light & Warmer

Model #	Description
<input type="checkbox"/> 790	Stealth Warmer
<input type="checkbox"/> 500	Stealth Heat/Light/Heat Combo

MOUNTING STYLES (SELECT ONE)

See installation page for more details.

Above Counter: Stainless Steel Counter

Under Counter: Stainless Steel Counter
(Requires under-counter reinforcement and access.)

Above Counter: Millwork Counter

Under Counter: Millwork Counter
(Compression installation not recommended for solid surface countertops.)

- EZ Mount - 2" x 8" Flange
- Heavy-Duty, Inverted Flange
- Heavy-Duty, Upright Flange
- Heavy-Duty Flange
- Heavy-Duty, Inverted Flange
- Heavy-Duty, Compression Flange
- Narrow, Inverted Flange
- Narrow, Upright Flange
- Narrow Flange
- Narrow, Inverted Flange
- Narrow, Compression Flange

AG2930-2

Double-Sided Self Serve w/Top Shelf

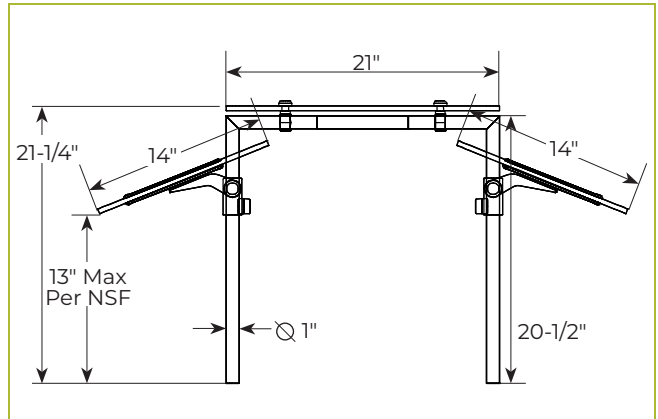
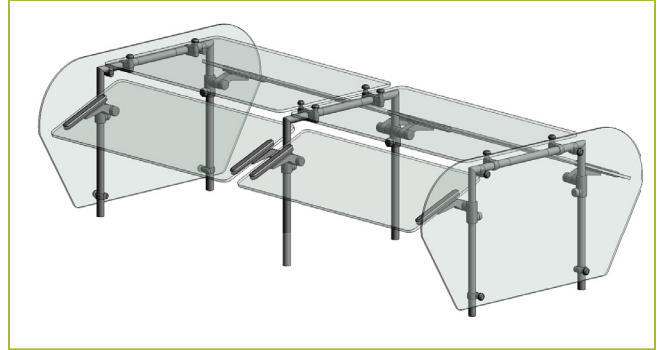

To meet NSF guidelines, end panels are included on all BSI quotations unless specifically excluded. (See end panel page for more details.)